

LAFFERTY EQUIPMENT MFG., INC. INSTALLATION / OPERATION INSTRUCTIONS

1035 / LC HOSE DROP STATION

Requirements

35 – 150* PSI Water

(Minimum flow rate, 10 GPM @ 35 PSI)

* If over 100 PSI, remove discharge ball valves.

30 – 100 PSI Air (Up to 7 SCFM)

3/4" I.D. Discharge Hose, 40' maximum

Water Temperature

Ambient – 140° F

**A convenient combination station
that offers the effectiveness of
FOAM CLEANING and the speed of
FLOOD SANITIZING**



OPTIONS

- *Air Gauge*
- *Water Gauge*
- *Water Regulator - for fluctuating pressures*
- *Backflow Preventer*
- *Stainless Steel Hose Rack*
- *1 Gallon Stainless Steel Jug Rack (round OR square)*
- *2 ½ Gallon Stainless Steel Jug Rack (inside dimensions 8 ½" x 10 ½")*
- *5 Gallon Stainless Steel Jug Rack (inside dimensions 12" x 12")*

**Model # 915120, 1035/LC Hose
Drop Station Complete
(with 40' combination Foam/Sanitize
hose, ball valve, wand, and nozzle)**

**1035/LC HDS also available in *Stainless Steel* - Model
915140**

INSTALLATION AND OPERATION INSTRUCTIONS

1035 / LC HOSE DROP STATION

CAUTION: Always observe good safety habits. Wear protective clothing, gloves, and eye wear. Direct discharge away from yourself and others. **SHUT DOWN AFTER EACH USE! NEVER LEAVE STATION UNATTENDED WITHOUT CLOSING ALL INCOMING VALVES AND RELIEVING PRESSURE IN THE HOSE.**

TO INSTALL (See Parts Diagram, Facing Page)

1. Mount the 1035/LC Hose Drop Station to a suitable surface.
2. **Station supplied without a backflow preventer. To prevent possible chemical back up into the water system, comply with local plumbing codes and install appropriate backflow preventer.** Then, connect your 35-150 PSI water and air lines.
3. Connect the wand assembly and QD socket to the hose as shown in the diagram. **[Hose must be 3/4" I.D., 40' maximum. Use *only* the 50250 nozzle supplied with the station. If your water pressure exceeds 100 PSI remove the discharge ball valve.]**
4. *Stapled to these instructions with a matching color-coded chart, are metering tips which control your chemical to water dilutions.* You will need to know the water pressure and the number of ounces of chemical needed per gallon of water to determine the correct tip colors. (See chemical label for manufacturer's recommendation.)
 - A. Locate your water pressure in the chart. The number below it is your water flow rate in **gallons per minute**.
 - B. Multiply the **gallons per minute** by the number of **ounces of chemical needed per gallon** of water.
 - C. Match your answer(s) to the *nearest* number in metering tip selection chart. **[Tip selection chart is based on water-thin chemical. Thicker chemicals will require a larger metering tip. If the selected metering tip does not produce desired foam consistency or chemical ratio, increase or decrease tip size until desired foam consistency or chemical ratio and cleaning results are achieved.]**

EXAMPLE OF METERING TIP SELECTION LC Foamer at 80 PSI

- 80 PSI = 1.76 GPM
- 4 ounces of chemical per gallon of water
- $1.76 \times 4 = 7.04$ ounces of chemical
- $7.04 \approx 7.0$ for thin chemical (Light Green tip)
1035 Sanitizer at 80 PSI
- 80 PSI = 11.10 GPM
- 1 ounce of chemical per 4 gallons of water
- $11.1 \times .25 = 2.78$ ounces of chemical
- $2.78 \approx 2.7$ for thin chemical (Pink tip)

- D. Open cover. Install selected metering tips into the solution check valves. Next, push the chemical tubes over the check valves and close cover. Immerse the chemical strainers into your chemical concentrates.

TO FOAM

1. Securely *quick connect* the hose to the foam QD plug. While firmly holding wand **point the discharge away from yourself and others**. Then, open the discharge ball valve. Open the foam ball valve and the air ball valve and observe foam quality.
2. Foam consistency can be changed by adjusting the air pressure.

AIR REGULATION PROCEDURES

Air pressure is very important for proper operation; air pressure must be LOWER than water pressure. Pull out adjustment knob on **air regulator**, and turn it *slowly clockwise* to increase air pressure until desired foam consistency is achieved. Make only slight adjustments, then wait to see the results. If the flow of foam surges and/or hose "bucks," you must decrease the air pressure by *slightly* turning the regulator **counterclockwise** until the foam stabilizes. "Fine tune" your adjustments by making *slight* turns **clockwise and/or counterclockwise** until foam is desired consistency. Once adjustments are made, push lock **air regulator**. If foam consistency is too wet or hose is still "bucking," try installing a larger **metering tip** and/or see Troubleshooting Guide (pg. 4).

3. Apply foam from the bottom and work up to prevent streaking.
4. When foaming is completed close the discharge ball valve. Return to the station and close foam ball valve. Then slowly re-open discharge valve. Expect a **strong** blast of foamy solution. After hose clears out, close the air ball valve.
5. Rinse the work surface before foam dries.

TO SANITIZE

1. Quick connect the hose to the sanitize QD plug. Close the discharge ball valve and open the sanitize ball valve. Move to the area to be sanitized, open the discharge ball valve and begin application.
2. When application is completed close the discharge ball valve. Return to station and close the sanitize ball valve. Re-open the discharge ball valve to relieve pressure in hose. Store hose on optional hose rack or reconnect to the foam QD plug and empty the hose with air.

WATER PRESSURE	40 PSI	60 PSI	80 PSI	100 PSI	125 PSI	150 PSI
1035 SANITIZER WATER FLOW RATE	8.60 GPM	9.90 GPM	11.10 GPM	12.30 GPM	14.30 GPM	15.80 GPM
LC FOAMER WATER FLOW RATE	1.34 GPM	1.54 GPM	1.76 GPM	1.91 GPM	2.02 GPM	2.15 GPM

The number under each color in the chart below represents the **average ounces of chemical which will pass through the tip per minute.**

METERING TIP SELECTION IN OUNCES PER MINUTE (AVERAGE)																				
COLOR	Brown	Clear	Bright Purple	White	Pink	Corn Yellow	Dark Green	Orange	Gray	Light Green	Medium Green	Clear Pink	Yellow Green	Burgundy	Pale Pink	Light Blue	Dark Purple	Navy Blue	Clear Aqua	Black
Thin Chemical	0.84	1.16	1.4	2.0	2.7	3.4	4.0	5.3	6.1	7.0	8.5	9.2	11.2	12.5	12.9	14.2	17.6	21.4	30.2	40.4

1035 / LC HOSE DROP STATION COMPLETE - Model # 915120

QTY.	CALL #	DESCRIPTION	PART #
1	1	STRAINER, "Y," NPB, 1/2"	150270
1	2	NIPPLE, HEX, 1/2"	429693
1	3	TEE, ST., 1/2"	692500
2	4	BALL VALVE, NPB, 1/2" FM(A)	413641
2	5	BUSHING, 3/4" x 1/2"	305225
1	6	INJECTOR BODY, 1035	385035
2	7	QUICK DISCONNECT, MALE PLUG, 1/2"	350459
1	8	QUICK DISCONNECT, SOCKET, 1/2"	350455
2	9	ELBOW, ST., POLY, 1/4"	257379
2	10	CHECK VALVE, SOLUTION, VITON BALL, 1/4"	491311
1	11	METERING TIPS, SET (20)	443798
2	12	TUBE, CHEMICAL, 1/4" x 6'	474745
2	13	STRAINER, CHEMICAL, HASTELLOY, 1/4"	150115
1	14	BUSHING, 1/2" x 3/8"	305221
1	15	NIPPLE, SS, 3/8" x 4"	429725
1	16	ELBOW, ST., 3/8"	257380
1	17	BALL VALVE, NPB, 3/8" FF(A)	413623
1	18	NIPPLE, HEX, 3/8"	429689
1	19	FOAMER BODY, LC	212135
1	20	CHECK VALVE, AIR, NPB, 1/4"	491302
1	21	ELBOW, ST., 1/4"	257378
1	22	COUPLING, HEX, 1/4"	506668
1	23	NIPPLE, SS, 1/4" x 2 1/2"	429704
1	24	BALL VALVE, 1/4" FFB	413602
1	25	NIPPLE, HEX, 1/4"	429686
1	26	REGULATOR, AIR, 1/4"	288360
1	27	HOSE, AIR, 1/4" x 24"	195182
1	28	SADDLE BRACKET ASSEMBLY W/ 3 PLATES	227114
2	29	U-BOLT ASSEMBLY, # 6 SQUARE	392486
1	30	PLATE, # 6 U-BOLT	398495
2	31	WASHER, 1/4" SS FLAT	398960
1	32	BASE & COVER, RF/SF	222114
1	33	NOZZLE, 1/2" - 50250	180152
1	34	HOSE, 3/4" x 40', 1/2" MPT BOTH ENDS	801241B
1	35	WAND, POLY, FOAM/SANITIZE	536603

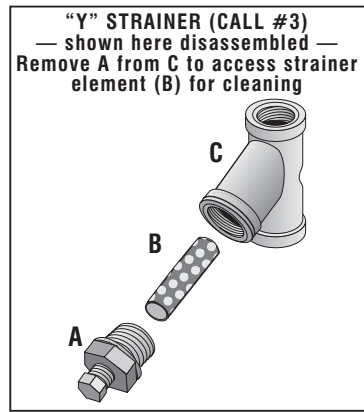

Compressed Air
30 - 100 PSI

Water Supply
35 - 150 PSI

Air
Regulator

Foam Ball
Valve

Air Ball
Valve

Sanitize
Ball Valve

Air Check
Valve

Solution
Check Valve

Metering
Tip

Foam QD
Plug

QD
Socket

Sanitize
QD Plug

Chemical
Strainer

Foam
Nozzle

For proper operation, use
ONLY the 50250 nozzle
supplied with your
1035/LC HDS.

Discharge
Ball Valve

For pressures over
100 PSI, remove the
discharge ball valve.

Station supplied without a backflow preventer.
Check local plumbing codes for requirements
in your area and **install appropriate backflow
preventer before operating.**

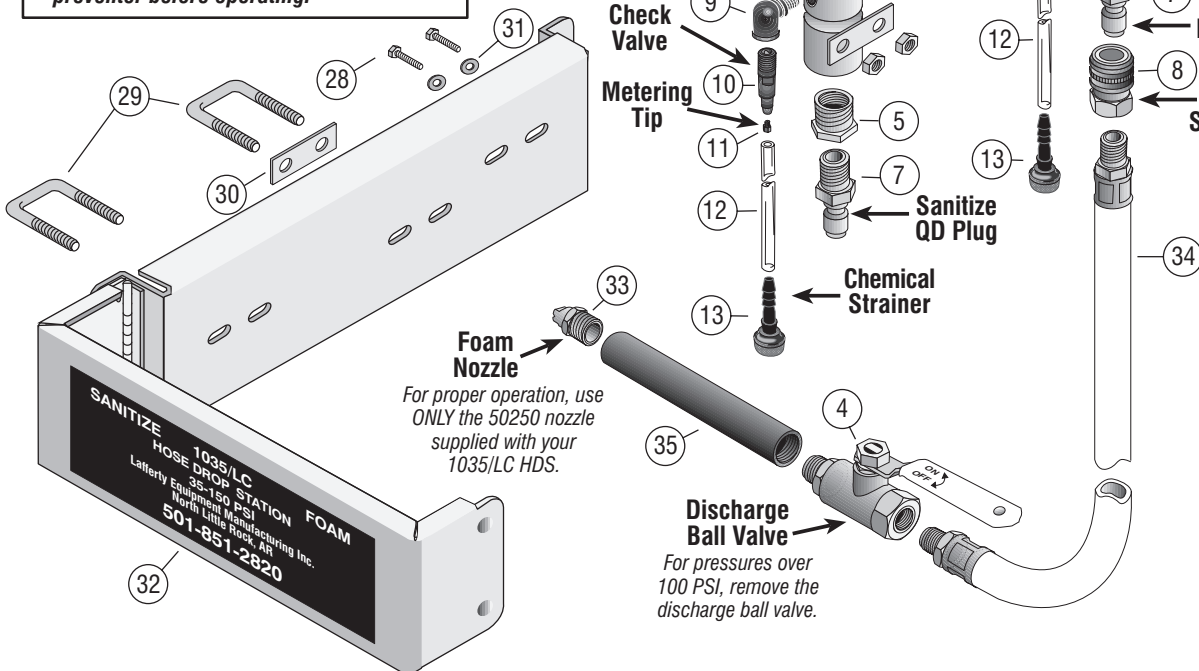

TROUBLESHOOTING GUIDE

for 1035 / LC HOSE DROP STATION

PROBLEMS WITH FOAMER	POSSIBLE CAUSE / SOLUTION																			
	1	2	3	4	5	6	7	8	9	10	11	12	13	14	15	16	17	18	19	20
A) Foamer will not draw chemical.	•			•		•	•	•	•	•		•	•	•	•					•
B) Foam surges and/or hose “bucks.”	•	•	•	•		•	•	•	•		•	•		•	•	•		•		•
C) Foam output too wet.		•	•	•	•	•	•	•			•	•	•	•	•			•		•
D) Foam output too dry.	•			•													•			
E) Water flowing into chemical container.										•										
F) Foam does not clean properly.												•						•	•	
G) Water/chemical backing up into air line.					•															

PROBLEMS WITH SANITIZER	POSSIBLE CAUSE / SOLUTION																			
	1	2	3	4	5	6	7	8	9	10	11	12	13	14	15	16	17	18	19	20
A) Sanitizer will not draw chemical.						•	•	•	•	•	•		•	•	•	•				•
B) Water flowing into chemical container.										•										
C) Chemical concentration too rich.																	•			
D) Chemical concentration too lean.					•													•		

POSSIBLE CAUSE / SOLUTION

- | | |
|--|---|
| <ol style="list-style-type: none"> 1. Air pressure too high for available water pressure – Adjust the air regulator slowly counterclockwise. 2. Use of an oiler on the airline will cause poor foam quality – Use only clean, dry air. 3. Inadequate air supply – Open air inlet valve fully. Adjust air regulator slowly clockwise. 4. Air regulator clogged or failed – Clean or replace air regulator. 5. Air check valve clogged or failed – Clean or replace the air check valve. 6. Water volume too low or pressure fluctuating, or temperature too high – Increase water volume and ensure water supply line is at least 3/4". Install a water regulator to stabilize pressure or decrease water temperature. 7. Foam/sanitize hose too long or wrong size or kinked; must be 3/4" I.D. – For pressure below 40 PSI, 25' is the maximum length recommended; for pressures over 40 PSI, 40' is the maximum. Straighten the hose. 8. Nozzle size too small – Must be a 50250 nozzle. 9. Water inlet and discharge ball valves not completely open – Completely open the water and discharge ball valves. | <ol style="list-style-type: none"> 10. Solution check valve clogged or failed – Clean or replace solution check valve. 11. “Y” strainer element clogged – Clean the water strainer element. (See diagram, page 3.) 12. Improper chemical – Ensure product is recommended for foaming and/or the application. 13. Chemical tube not immersed in chemical or chemical depleted – Immerse tube or replenish. 14. Chemical strainer or metering tip blocked – Clean or replace chemical strainer and/or tip. 15. Chemical tube stretched out where tube slides over check valve or pin hole/cut in chemical tube – Cut approximately 1/2" off end of tube or replace tube. 16. Vacuum leak in chemical pick-up assembly – Tighten the connection(s). 17. Chemical to water ratio too high – Install smaller tip. 18. Chemical to water ratio too low – Install larger tip. 19. Soil has hardened on surface – Reapplication may be necessary. Always rinse foam before it dries. 20. Water scale or chemical build-up may have formed in the foamer body or the injector body causing poor pick-up – To descale, carefully remove body and soak <i>entire</i> foamer or injector body in descaling acid. |
|--|---|

Lafferty Equipment Manufacturing, Inc.

5614 Oak Grove Road

North Little Rock, AR 72118

Telephone: (501) 851-2820 — FAX: (501) 851-3719

Made in the USA

Distributed by: