

# LAFFERTY EQUIPMENT MFG., INC.

## INSTALLATION / OPERATION INSTRUCTIONS

### HPSS SANITIZE / RINSE / FOAM HOSE DROP STATION

#### Requirements

400 – 1000 PSI Water — Up to 10 GPM  
50 – 100 PSI Air — Up to 12 SCFM  
1/2" I.D. Discharge Hose  
3/8" I.D. Discharge Hose

Water Temperature  
Ambient to 160° F



## OPTIONS

- *00250 Nozzle, part # 180153 (increases foam throw distance from 7' with the standard 50250 fan nozzle to 20')*
- *Stainless Steel "Y" Strainer*
- *Stainless Steel Hose Rack*
- *1 Gallon Stainless Steel Jug Rack (round OR square)*
- *2 ½ Gallon Stainless Steel Jug Rack (inside dimensions 8 ½" x 10 ½")*
- *5 Gallon Stainless Steel Jug Rack (inside dimensions 12" x 12")*

Model # 918125-W10SS  
Model # 918127-W20SS  
(with nozzles only)

Model # 918225-W10SS Complete  
Model # 918227-W20SS Complete  
(with 50' hose assemblies and nozzles)

**For Lower Pressures or Higher Foam Volume,  
choose our LC and LPSS Hose Drop Stations**

# HPSS SANITIZE/RINSE/FOAM HOSE DROP STATION INSTRUCTIONS

## TO INSTALL (See Parts Diagram, Facing Page)

1. Mount the HPSS Sanitize/Rinse/Foam Hose Drop Station to a suitable surface.
2. Connect your water and air lines to the station (see diagram).
3. Connect the foam wand, trigger gun assembly, and QD socket to the hoses as shown in diagram. **[Foam hose must be 1/2" I.D. Rinse/Sanitize hose must be 3/8" I.D. Use only the nozzles supplied with station.]**
4. *Stapled to these instructions, with a matching color-coded chart, are metering tips which control your chemical to water dilutions. You will need to know the water pressure and the number of ounces of chemical needed per gallon of water to determine the correct tip color. (See chemical label for manufacturer's recommendation.)*
  - A. Locate your water pressure in the chart. The number below it is your water flow rate in **gallons per minute**.
  - B. Multiply the **gallons per minute** by the number of **ounces of chemical needed per gallon** of water.
  - C. Match answer(s) to the *nearest* number in metering tip selection chart. **[The tip selection chart is based on water-thin chemical. Thicker chemicals will require a larger metering tip. If the selected metering tip does not produce desired foam consistency, increase or decrease tip size until desired foam consistency or chemical ratio and cleaning results are achieved.]**

### EXAMPLE OF METERING TIP SELECTION HPSS Foamer at 600 PSI

- 600 PSI = 1.5 GPM
  - 4 ounces of chemical per gallon of water
  - 1.5 x 4 = 6 ounces of chemical
  - 6 ≈ 6.1 for thin chemical (Gray tip)
- ### W20 Sanitizer at 700 PSI
- 700 PSI = 4.0 GPM
  - 1 ounce of chemical per 4 gallons of water
  - 4.0 x .25 = 1.0 ounces of chemical
  - 1.0 ≈ 1.16 for thin chemical (Clear tip)

- D. Open cover. Install selected metering tip into solution check valves. Next, push chemical tubes over the check valves and close cover. Immerse the chemical strainers into your chemical concentrates.

## TO FOAM

1. While firmly holding foam wand, **point discharge away from yourself and others**. Then, completely open the foam ball valve. Completely open the air ball valve and observe foam quality.
2. Foam consistency can be changed by adjusting the air volume with the needle valve. For **drier** foam, turn the needle valve **counterclockwise**. For **wetter** foam, turn the needle valve **clockwise**. If foam is still too wet or hose is "bucking" after adjustments are made, try installing a larger metering tip.
3. To prevent streaking, apply foam in a thin layer *from the bottom and work up*.
4. When foaming is completed, return to the station and close the foam ball valve. After hose clears out, close the air ball valve. **Do not attempt to cut off flow of foam by restricting or "kinking" hose.**
5. Rinse the work surface before foam dries.

## TO RINSE

1. Securely quick connect the rinse/sanitize hose to the rinse QD plug. With gun in hand, open the rinse ball valve. Move to the area to be rinsed. Then, depress the trigger on the gun and begin rinsing.
2. When rinsing is completed, return to the station and close the rinse ball valve. Before attempting to remove the hose, depress trigger to relieve pressure in hose.

## TO SANITIZE (NOTE: Do not change the nozzle size, nozzle MUST match sanitizer.)

1. **After relieving pressure in hose**, securely quick connect the rinse/sanitize hose assembly to the sanitize QD plug.
2. Open the sanitize ball valve. Move to the area to be sanitized. Then, depress the trigger on the gun and begin sanitizing.
3. When finished sanitizing, return to the station and close the sanitize ball valve. Depress trigger to relieve pressure in the hose.
4. If needed, reconnect rinse/sanitize hose assembly to rinse QD plug and repeat rinse operation. Store hose — optional hose rack is available.

**CAUTION: Always observe good safety habits. Wear protective clothing, gloves, and eye wear. Direct discharge away from yourself and others. DO NOT attempt to stop flow of foam by restricting or "kinking" hose. DO NOT install a ball valve at the end of the foam hose.**

WATER PRESSURE	400 PSI	500 PSI	600 PSI	700 PSI	800 PSI	900 PSI	1000 PSI
HPSS FOAMER WATER FLOW RATE	1.3 GPM	1.4 GPM	1.5 GPM	1.6 GPM	1.74 GPM	1.89 GPM	1.96 GPM

SANITIZER	NOZZLE SIZE	SANITIZER WATER FLOW RATE							
		400 PSI	500 PSI	600 PSI	700 PSI	800 PSI	900 PSI	1000 PSI	
W10	2510	1.3 GPM	1.4 GPM	1.5 GPM	1.6 GPM	1.74 GPM	1.89 GPM	1.96 GPM	
W20	2520	3.0 GPM	3.4 GPM	3.7 GPM	4.0 GPM	4.2 GPM	4.65 GPM	4.8 GPM	

The number under each color in the chart below represents the **average ounces of water-thin chemical which will pass through the tip per minute.**

METERING TIP SELECTION IN OUNCES PER MINUTE (AVERAGE)																					
COLOR	Brown	Clear	Bright Purple	White	Pink	Corn Yellow	Dark Green	Orange	Gray	Light Green	Medium Green	Clear Pink	Yellow Green	Burgundy	Pale Pink	Light Blue	Dark Purple	Navy Blue	Clear Aqua	Black	
Thin Chemical	0.84	1.16	1.4	2.0	2.7	3.4	4.0	5.3	6.1	7.0	8.5	9.2	11.2	12.5	12.9	14.2	17.6	21.4	30.2	40.4	

# HPSS SANITIZE/RINSE/FOAM HOSE DROP STATION COMPLETE

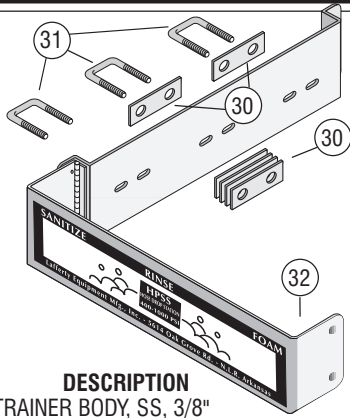

QTY.	CALL #	DESCRIPTION	PART #
1	1	STRAINER BODY, SS, 3/8"	552020
1	2	STRAINER ELEMENT	552009
1	3	STRAINER ADAPTER, SS, 1/8"	552005
1	4	STRAINER CAP, SS	552004
1	5	BUSHING, 3/8" x 1/8"	305212
1	6	CROSS, 3/8"	645407
2	7	NIPPLE, SS, 3/8" x 4"	429725
2	8	ELBOW, ST., 3/8"	257380
3	9	BALL VALVE, SS, 3/8"	413659
2	10	NIPPLE, SS, 3/8" x 2"	429713
1	11	INJECTOR BODY, W-10, SS, 3/8"	382010
1	11	INJECTOR BODY, W-20, SS, 3/8"	382020
2	12	QUICK DISCONNECT, FE PLUG, 3/8"	350443
1	13	QUICK DISCONNECT, FE SOCKET, 3/8"	350446
3	14	ELBOW, ST., 1/4"	257378
2	15	CHECK VALVE, SOLUTION, SS, 1/4"	491324
1	16	METERING TIPS, SET (20)	443798
2	17	TUBE, CHEMICAL, 1/4" x 6'	474745
2	18	STRAINER, CHEMICAL, HASTELLOY, 1/4"	150115
1	19	NIPPLE, SS, CLOSE, 3/8"	429740
1	20	NIPPLE, SS, 3/8" x 6"	429735
1	21	NIPPLE, SS, 3/8" x 1 1/2"	429711
1	22	FOAMER BODY, HPSS	212111
1	23	HOSE BARB, 1/2" x 1/2" MPT	119272
1	24	CHECK VALVE, AIR, SS, 1/4"	491306
1	25	COUPLING, HEX, 1/4"	506668
1	26	NEEDLE VALVE, 1/4"	660797
1	27	NIPPLE, HEX, 1/4"	429686
1	28	BALL VALVE, 1/4" FFB	413602
1	29	HOSE, AIR, 1/4" x 24"	195182
6	30	PLATE, # 6 U-BOLT	398495
3	31	U-BOLT ASSEMBLY, #6 SQUARE	392486
1	32	BASE & COVER, S/R/F	222115
1	33	NOZZLE, SS, 2510 } MATCHES	180126
1	33	NOZZLE, SS, 2520 } SANITIZER	180131
1	34	NOZZLE, 1/2", 50250	180152
1	35	HOSE, 3/8" x 50' BNM, AFR	195050
1	36	GUN, JA, TRIGGER	320425
1	37	WAND, SS, 1/4" x 18"	536518
1	38	HOSE CLAMP, 1/2"	134302
1	39	HOSE, 1/2" x 50', 1/2" MPT (ONE END)	803650
1	40	WAND, POLY, FOAM/SANITIZE	536603

These items are not included with the HPSS Sanitize/Rinse/Foam HDS Model #s 918125, and 918127.

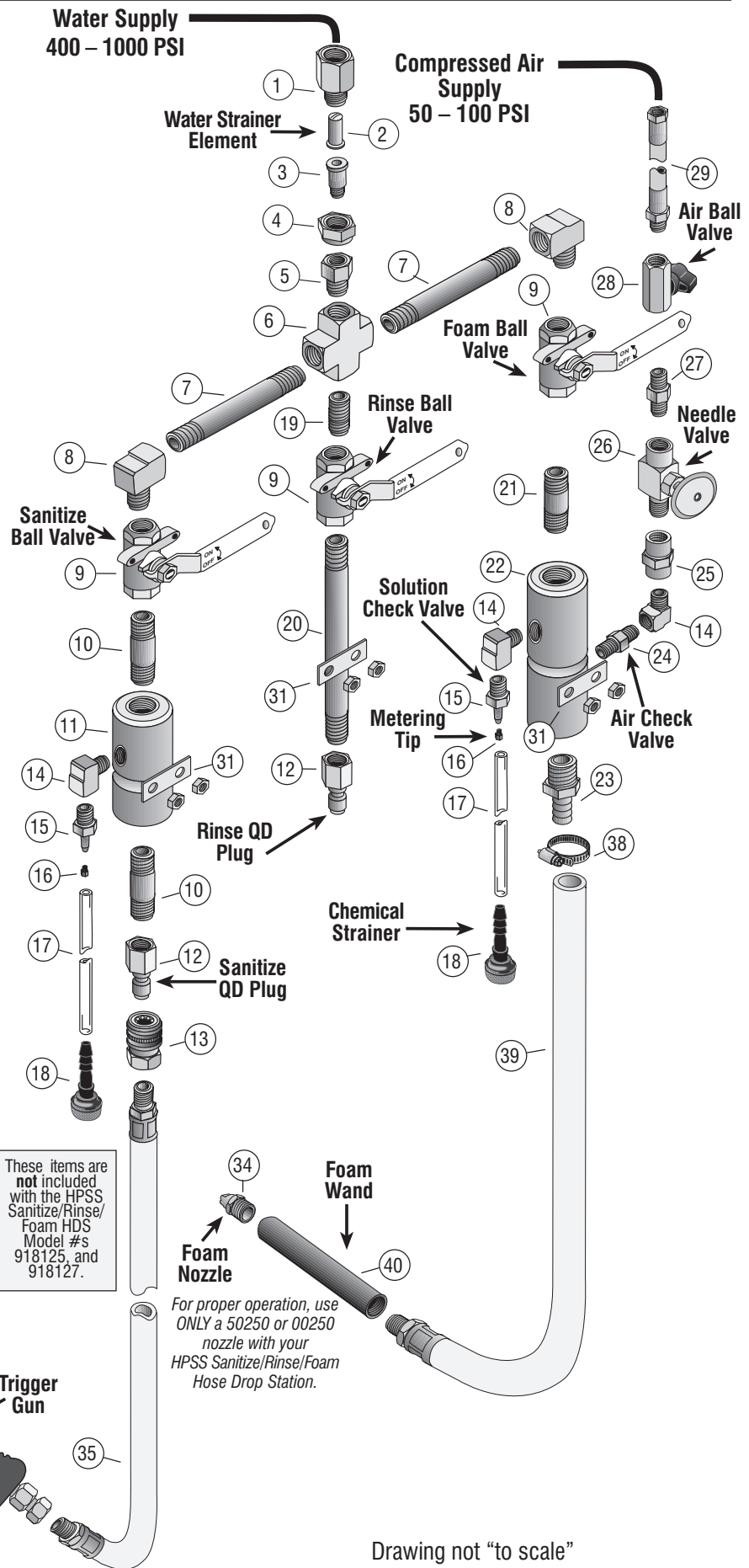

For proper operation, use ONLY the nozzle supplied with your HPSS Sanitize/Rinse/Foam Hose Drop Station.

For proper operation, use ONLY a 50250 or 00250 nozzle with your HPSS Sanitize/Rinse/Foam Hose Drop Station.

Drawing not "to scale"

# TROUBLESHOOTING GUIDE *for* HPSS SANITIZE/RINSE/FOAM HOSE DROP STATION

PROBLEMS WITH FOAMER	POSSIBLE CAUSE / SOLUTION																		
	1	2	3	4	5	6	7	8	9	10	11	12	13	14	15	16	17	18	19
A) Foamer will not draw chemical.	•					•	•	•	•	•		•	•	•	•				•
B) Foam surges and/or hose "bucks."	•	•	•	•		•	•	•		•	•		•	•	•		•		•
C) Foam output too wet.		•	•	•	•	•	•	•		•	•	•	•	•	•		•		•
D) Foam output too dry.	•																•		
E) Water flowing into chemical container.										•									
F) Foam does not clean properly.											•							•	•
G) Water/chemical backing up into air line.					•														

PROBLEMS WITH SANITIZER	POSSIBLE CAUSE / SOLUTION																		
	1	2	3	4	5	6	7	8	9	10	11	12	13	14	15	16	17	18	19
A) Sanitizer will not draw chemical.						•	•	•	•	•		•	•	•	•				•
B) Water flowing into chemical container.										•									
C) Chemical concentration too rich.																	•		
D) Chemical concentration too lean.						•												•	

## Possible Cause / Solution

- |   |  |
|---|--|
| <ol style="list-style-type: none"> <li>1. <b>Air volume too high</b> – Slightly adjust the needle valve (clockwise).</li> <li>2. <b>Use of an oiler on the airline will cause poor foam quality</b> – Use only clean, dry air.</li> <li>3. <b>Inadequate air supply</b> – Open air inlet valve fully/adjust needle valve (counterclockwise).</li> <li>4. <b>Air volume too low or needle valve clogged</b> – Adjust needle valve counterclockwise or clean/replace valve.</li> <li>5. <b>Air check valve clogged or failed</b> – Clean or replace the air check valve.</li> <li>6. <b>Temperature too high</b> – Decrease water temperature.</li> <li>7. <b>Foam and/or sanitize hose too long or wrong size or kinked; must be 1/2" I.D. (foam) or 3/8" I.D. (sanitize)</b> – Maximum recommended length is 75'. Straighten the hose.</li> <li>8. <b>Nozzle size too small</b> – Foam nozzle must be a 50250 or 00250 nozzle. Sanitize nozzle must match injector (see chart, pg. 2).</li> <li>9. <b>Solution check valve clogged or failed</b> – Clean or replace solution check valve.</li> <li>10. <b>Water strainer element clogged</b> – Clean the water strainer element. [Completely unscrew strainer cap from strainer for easy cleaning or replacement of strainer element; see diagram, pg. 3.]</li> </ol> | <ol style="list-style-type: none"> <li>11. <b>Improper chemical</b> – Ensure product is recommended for foaming and/or the application.</li> <li>12. <b>Chemical tube not immersed in chemical or chemical depleted</b> – Immerse tube or replenish.</li> <li>13. <b>Chemical strainer or metering tip blocked</b> – Clean or replace chemical strainer and/or tip.</li> <li>14. <b>Chemical tube stretched out where tube slides over check valve or pin hole/cut in chemical tube</b> – Cut approximately 1/2" off end of tube or replace tube.</li> <li>15. <b>Vacuum leak in chemical pick-up assembly</b> – Tighten the connection(s).</li> <li>16. <b>Chemical to water ratio too high</b> – Install smaller tip.</li> <li>17. <b>Chemical to water ratio too low</b> – Install larger tip.</li> <li>18. <b>Soil has hardened on surface</b> – Reapplication may be necessary. Always rinse foam before it dries.</li> <li>19. <b>Water scale or chemical build-up may have formed in the foamer body or the injector body causing poor pick-up</b> – To descale, carefully remove body and soak <i>entire</i> foamer or injector body in descaling acid.</li> </ol> |
|---|--|

**Lafferty Equipment Manufacturing, Inc.**

5614 Oak Grove Road • North Little Rock, AR 72118 • Telephone: (501) 851-2820 • FAX: (501) 851-3719

*Made in the U.S.A.*