

# LAFFERTY EQUIPMENT MFG., INC. INSTALLATION / OPERATION INSTRUCTIONS

## ULTIMATE HC FOAMER

### Requirements

25 – 100 PSI Water — Up to 3 GPM  
25 – 100 PSI Air — Up to 7 SCFM  
3/4" I. D. Discharge Hose, 50250 Nozzle

### Water Temperature

Ambient to 140° F

The Lafferty Ultimate High Concentrate Foamer is designed for those *tough cleaning jobs* which require a **thick chemical** and/or a **high concentration of chemical**.



## OPTIONS

- *Air Gauge*
- *Water Gauge*
- *Water Regulator - for fluctuating water pressure*
- *Backflow Preventer*
- *Stainless Steel Hose Rack*

Model # 914000, Ultimate HC Foamer  
(with nozzle only)

Model # 914050, Ultimate HC Foamer Complete  
(with 50' hose, ball valve, wand, and nozzle)

Ultimate Foamer also available in *Stainless Steel* - Model # 915015.

# ULTIMATE HC FOAMER INSTALLATION / OPERATION INSTRUCTIONS

## IMPORTANT: FOAMER SUPPLIED WITHOUT A BACKFLOW PREVENTER

TO PREVENT POSSIBLE CHEMICAL BACK UP INTO THE WATER SYSTEM, COMPLY WITH LOCAL PLUMBING CODES AND INSTALL APPROPRIATE BACKFLOW PREVENTER BEFORE OPERATING.

CAUTION: ALWAYS OBSERVE GOOD SAFETY HABITS. WEAR PROTECTIVE CLOTHING, GLOVES, AND EYE WEAR. DIRECT DISCHARGE AWAY FROM YOURSELF AND OTHERS.

## TO INSTALL (See Parts Diagram, Facing Page)

1. Mount the Ultimate HC Foamer to a suitable surface.
  2. **Foamer supplied without a backflow preventer. To prevent possible chemical back up into the water system, comply with local plumbing codes and install appropriate backflow preventer before operating.** Then, connect your 25 – 100 PSI water and air to the foamer.
  3. Connect the foam hose to the hose barb and secure with the clamp. **[Foam hose must be 3/4" I. D.]**
  4. Connect the foam wand assembly to the hose. **[Use only the 50250 nozzle supplied with foamer.]**
  5. *Stapled to these instructions, with a matching color-coded chart, are metering tips which control your chemical to water dilutions. [THIS IS A HIGH CONCENTRATE UNIT. Although metering tips and selection instructions are provided, do not install a tip if you want to achieve the strongest possible chemical concentration.]* If you will not be using a metering tip go to step E. If you will be using a metering tip, you will need to know the water pressure and the number of ounces of chemical needed per gallon of water to determine the correct tip color. (See chemical label for manufacturer's recommendation.)
- A. Locate your water pressure in the chart. The number below it is your water flow rate in **gallons per minute**.
- B. Multiply the **gallons per minute** by the number of **ounces of chemical needed per gallon** of water.
- C. Match answer to the *nearest* number in the metering tip selection chart. **[The tip selection chart is based on water-thin chemical. Thicker chemicals will require a larger metering tip. If the selected metering tip does not produce desired foam consistency, increase tip size until desired foam consistency and cleaning results are achieved.]**
- EXAMPLE OF METERING TIP SELECTION**  
**ULTIMATE HC Foamer at 50 PSI**

  - 50 PSI = 1.46 GPM
  - 4 ounces of chemical per gallon of water
  - 1.46 x 4 = 5.84 ounces of chemical
  - 5.84 ≈ 6.1 for thin chemical (Gray tip)
  - (thicker chemicals will require a larger tip)
- D. Install selected metering tip into the solution check valve.
- E. Push the chemical tube over the check valve. Immerse the chemical strainer into your chemical concentrate.

## Air Adjustment Guidelines

For desired foam consistency, you may need to adjust the air pressure with the air regulator and the volume with the needle valve. To make adjustments, turn the regulator knob 1/4 of a revolution at a time. Then, turn the needle valve slightly. Wait to see the results before continuing.

**[Chemical concentration is directly affected by air pressure and volume. Generally speaking, lower air pressure/volume yields wetter foam and the strongest possible chemical concentration.]**

## TO OPERATE

1. Make sure the needle valve is turned completely **clockwise**. Then, turn the needle valve 1 - 2 *complete* turns **counterclockwise**. Next, pull out the adjustment knob on the air regulator.
2. While firmly holding the foam wand, **point the discharge away from yourself and others**. Then, open the discharge ball valve. Open the water ball valve and the air ball valve and observe foam quality. If foam is too wet:
  - A. Turn air regulator knob **clockwise** to increase pressure until foam is desired consistency. If flow of foam surges and/or becomes too dry, turn the needle valve slightly **clockwise** to decrease volume until foam is desired consistency. Wait to see the results before continuing. It may be necessary to "fine tune" your adjustments by turning the regulator and needle valve **clockwise** and/or **counterclockwise** until foam is desired consistency.
  - B. If foam is still too wet or surging after trying all combinations of adjustments, try installing a larger metering tip and/or see Troubleshooting Guide (pg. 4). When foam is desired consistency, push lock the air regulator.
3. Foam from the bottom and work up to prevent streaking.
4. When foaming is completed, close the discharge ball valve. Return to foamer and close the water supply valve. Then slowly re-open the discharge valve. Expect a strong blast of foamy solution. After hose is cleared out, close the air ball valve and store the hose.
5. Rinse the work surface before foam dries.

**CAUTION: SHUT DOWN AFTER EACH USE! NEVER LEAVE FOAMER UNATTENDED WITHOUT CLOSING THE INCOMING WATER AND AIR VALVES AND RELIEVING PRESSURE IN THE HOSE.**

WATER PRESSURE	30 PSI	40 PSI	50 PSI	60 PSI	70 PSI	80 PSI	90 PSI	100 PSI
<b>ULTIMATE HC FOAMER WATER FLOW RATE</b>	1.29 GPM	1.34 GPM	1.46 GPM	1.54 GPM	1.59 GPM	1.76 GPM	1.8 GPM	1.91 GPM

The number under each color in the chart below represents the **average ounces of water-thin chemical which will pass through the tip per minute**.

METERING TIP SELECTION IN OUNCES PER MINUTE (AVERAGE)																				
COLOR	Brown	Clear	Bright Purple	White	Pink	Corn Yellow	Dark Green	Orange	Gray	Light Green	Medium Green	Clear Pink	Yellow Green	Burgundy	Pale Pink	Light Blue	Dark Purple	Navy Blue	Clear Aqua	Black
<b>Thin Chemical</b>	0.84	1.16	1.4	2.0	2.7	3.4	4.0	5.3	6.1	7.0	8.5	9.2	11.2	12.5	12.9	14.2	17.6	21.4	30.2	40.4

# ULTIMATE HC FOAMER COMPLETE - Model # 914050

**IMPORTANT:** Foamer supplied without a backflow preventer. Check local plumbing codes for requirements in your area and **install appropriate backflow preventer before operating.**

**"Y" STRAINER (CALL # 3)**  
— shown here disassembled —  
Remove A from C to access strainer element (B) for cleaning

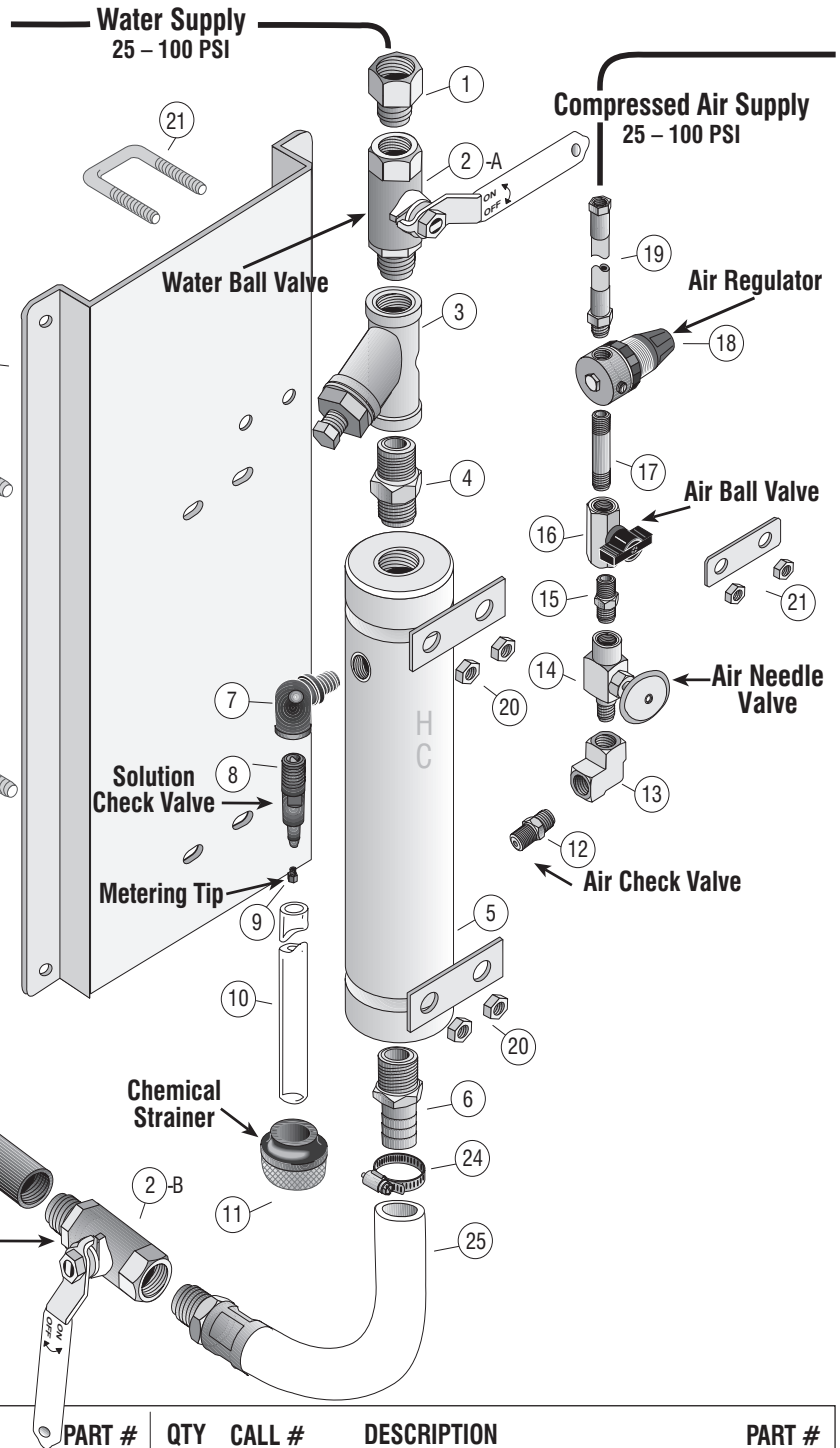
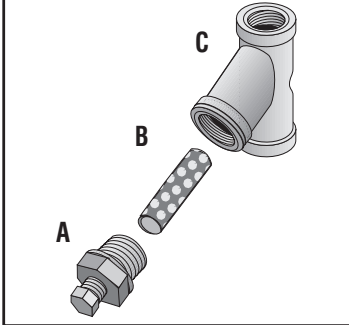

For proper operation, use ONLY the 50250 nozzle supplied with your Ultimate HC Foamer.

QTY	CALL #	DESCRIPTION	PART #	QTY	CALL #	DESCRIPTION	PART #
1	1	ADAPTER, FGH x 1/2" MPT	102027	1	15	NIPPLE, HEX, 1/4"	429686
1	2- A	BALL VALVE, NPB, 1/2" FM(A)	413641	1	16	BALL VALVE, 1/4" FFB	413602
1	3	STRAINER, "Y", NPB, 1/2"	150270	1	17	NIPPLE, SS, 1/4" x 2"	429702
1	4	NIPPLE, HEX, 1/2"	429693	1	18	REGULATOR, AIR, 1/4"	288360
1	5	FOAMER BODY, ULTIMATE HC	212051	1	19	HOSE, AIR, 1/4" x 24"	195182
1	6	HOSE BARB, 3/4" x 3/4" MPT	119288	2	20	U-BOLT ASSEMBLY, #8 SQUARE	392498
1	7	ELBOW, ST., POLY, 1/4"	257379	1	21	U-BOLT ASSEMBLY, #6 SQUARE	392486
1	8	CHECK VALVE, SOL., VITON BALL, 1/4"	491311	1	22	BASE, ULTIMATE FOAMER	222560
1	9	METERING TIPS, SET (20)	443798	1	23	NOZZLE, 1/2" - 50250	180152
1	10	TUBE, CHEMICAL, 7/16" x 6'	474749	1	24	HOSE CLAMP, 3/4"	134306
1	11	STRAINER, MONEL, 3/8"	150119	1	25	FOAM HOSE, 3/4" x 50', 1/2" MPT	801242
1	12	CHECK VALVE, AIR, SS, 1/4"	491306	1	2-B	BALL VALVE, NPB, 1/2" FM(A)	413641
1	13	ELBOW, 90°, 1/4"	257358	1	26	WAND, POLY, FOAM/SANITIZE	536603
1	14	NEEDLE VALVE, 1/4"	660797	These 4 items are <b>not</b> included with the #914000 Ultimate HC Foamer.			

# TROUBLESHOOTING GUIDE

for

## ULTIMATE HC FOAMER

**PREVENTIVE MAINTENANCE:** When the foamer will be out of service for extended periods, the risk of residual chemical build-up is increased. To prevent build-up, remove chemical tube from chemical concentrate and place it in warm water. Completely open the water supply valve for 30 seconds to flush. Check and/or clean chemical strainer; replace if missing.

PROBLEMS	POSSIBLE CAUSE / SOLUTION																			
	1	2	3	4	5	6	7	8	9	10	11	12	13	14	15	16	17	18	19	20
A) Foamer will not draw chemical.	•			•		•	•	•	•	•	•		•	•	•	•				•
B) Foam surges and/or hose "bucks."	•	•	•	•		•	•	•	•		•	•		•	•	•		•		•
C) Foam output too wet.		•	•	•	•	•	•	•	•		•	•	•	•	•	•		•		•
D) Foam output too dry.	•			•													•			
E) Water flowing into chemical container.										•										
F) Foam does not clean properly.												•						•	•	
G) Water/chemical backing up into air line.					•															

## POSSIBLE CAUSE / SOLUTION

- Air pressure/volume too high for available water pressure** – Slightly adjust needle valve clockwise and/or adjust the air regulator slowly counterclockwise.
- Use of an oiler on the airline will cause poor foam quality** – Use only clean, dry air.
- Inadequate air supply** – Open air inlet valve fully/adjust needle valve counterclockwise and/or air regulator clockwise.
- Needle valve and/or air regulator clogged or failed** – Clean or replace needle valve or air regulator.
- Air check valve clogged or failed** – Clean or replace the air check valve.
- Water pressure fluctuating or temperature too high** – Install a water regulator to stabilize pressure or decrease water temperature.
- Foam hose too long or wrong size or kinked; must be 3/4" I.D.** – For pressure below 65 PSI, 50' is the maximum length **recommended**; for pressures over 65 PSI, 75' is the maximum. Straighten the hose.
- Nozzle size too small** – Must be a 50250 nozzle.
- Water inlet and discharge ball valves not completely open** – Completely open the water and discharge ball valves.
- Solution check valve clogged or failed** – Clean or replace solution check valve.
- "Y" strainer element clogged** – Clean the water strainer element. (See diagram, page 3.)
- Improper chemical** – Ensure product is recommended for foaming and/or the application.
- Chemical tube not immersed in chemical or chemical depleted** – Immerse tube or replenish.
- Chemical strainer or metering tip blocked** – Clean or replace chemical strainer and/or tip.
- Chemical tube stretched out where tube slides over check valve or pin hole/cut in chemical tube** – Cut approximately 1/2" off end of tube or replace tube.
- Vacuum leak in chemical pick-up assembly** – Tighten the connection(s).
- Chemical to water ratio too high** – Install **smaller** tip.
- Chemical to water ratio too low** – Install **larger** tip.
- Soil has hardened on surface** – Reapplication may be necessary. Always rinse foam **before** it dries.
- Water scale or chemical build-up may have formed in the foamer body causing poor pick-up** – To descale, carefully remove body and soak *entire* foamer body in descaling acid.

**Lafferty Equipment Manufacturing, Inc.**

5614 Oak Grove Road  
North Little Rock, AR 72118

Telephone: (501) 851-2820 — FAX: (501) 851-3719

Made in the USA

Distributed by: